

# Metalbestos Chimney Systems (US Only – See separate instructions for Canada)

# S-2

# Installation Instructions

## Covering - Fire Stops & Attic Insulation Shields

Read Sheet GS for important clearance and safety precautions before installing any of the parts described by this sheet. Sheet GS is packaged with Supports.

**⚠ WARNING**

Failure to follow the instructions could cause **FIRE, CARBON MONOXIDE POISONING, OR DEATH.** If you are unsure of installation requirements, call the Phone Number listed on the instructions or sizing handbook.

### FIRESTOPPING

Wherever a chimney passes through a ceiling or floor, through a wall, or into an enclosure, it must be firestopped. Metalbestos Chimney System (MCS) parts which act as fire stops include:

1. Ceiling Support (CSP), and Finish Support Package (FSP). Their primary use is for chimney support, but the round or square trim plate on the part is specifically intended to close and firestop the framed opening around the chimney.
2. Fire Stop/Wall Spacer (WS), for use (with Model SSII only) in vertical enclosures, and for wall openings on the outdoor side. (See Fig. 1A)
3. Fire Stop/Joist Shield (JS) for use (with all MCS models) in vertical enclosures where the MCS passes through a floor / ceiling opening. It can be either under the ceiling or between the finish ceiling and the joists. See Fig. 3A and 3B.

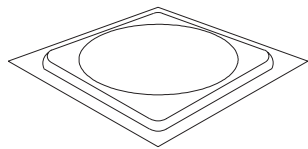

Firestop/Wall Spacer (T-WS)  
Used With SSII Only

FIG. 1A

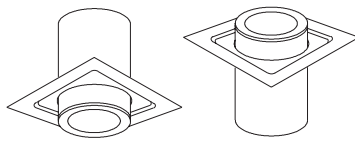

Firestop/Joist Shield (T-JS)  
Used With MCS Chimney

FIG. 1B

4. Fire Stop/Trim Collar (TCS), for use (with Model SSII only) at exposed ceilings and also for the indoor or appliance side of a SSII chimney which penetrates a wall. (See Fig. 2A)
5. Fire Stop/Trim Plate (TPS), for use with all MCS models at exposed ceilings. (See Fig. 2B)

4. Fire Stop/Trim Collar (TCS), for use (with Model SSII only) at exposed ceilings and also for the indoor or appliance side of a SSII chimney which penetrates a wall. (See Fig. 2A)

5. Fire Stop/Trim Plate (TPS), for use with all MCS models at exposed ceilings. (See Fig. 2B)

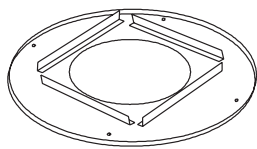

Firestop/Trim Collar (TCS) For  
Open Flat Ceilings Used With  
SSII Only

FIG. 2A

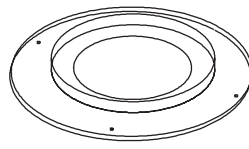

Firestop/Trim Plate (TPS) For  
Open Flat Ceilings Used With  
MCS Chimney

FIG. 2B

A fire stop performs the following essential functions for both the dwelling and the chimney:

1. Together with a fully framed opening (all four sides) it controls vertical and horizontal spread of any fire external to the chimney.
2. It stabilizes the chimney in the framed opening and defines and maintains the required two inch AIR SPACE clearance to combustibles.

3. It prevents heat losses from the dwelling by blocking vertical air circulation in the space around the chimney.

4. When located at a ceiling below a roof flashing (or below a roof support) it helps provide stability for that portion of the chimney extending above the roof.

### INSTALLATION REQUIREMENTS

The selected type of Fire Stop must be the correct size for the chimney. It will always be installed from below, and secured either to the underside of the framed opening, or to the ceiling.

The dished plate Fire Stop/Wall Spacer (WS) (for use only with SSII) and the Fire Stop/Joist Shield (JS) (for use with all MCS chimneys) may be either under the ceiling or between the finish ceiling and the joists. See Fig. 3A and 3B.

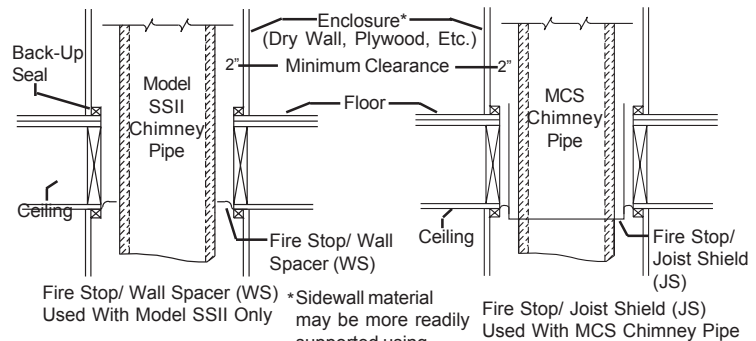
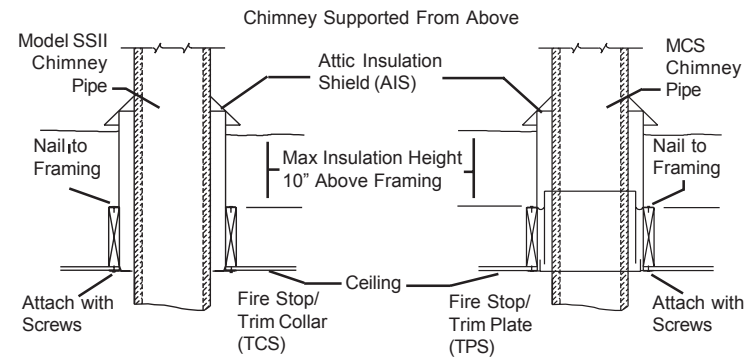

FIG. 3A

FIG. 3B

\*Sidewall material may be more readily supported using back-up strips at upper and lower ends of an enclosure.

The round Fire Stop/Trim Collar (TCS) (for use only with SSII) and the (Fire Stop/Trim Plate (TPS) (for use with all MCS chimneys) is intended only to be used below the ceiling. See Fig. 4A and 4B.



Fire Stop/Trim Collar (TCS) Used Below Ceiling Used With Model SSII Only

FIG. 4A

Fire Stop/Trim Plate (TPS) Used Below Open Ceiling Used With MCS Chimney Pipe

FIG. 4B

### To Install:

1. Frame a level square opening for 2 inches AIR SPACE clearance from the outside of the chimney to the framing.
2. Temporarily install the Fire Stop (WS) [SSII only] or JS [all MCS models] together with a length of chimney through the opening to check chimney positioning and clearance.

- Use nails to secure Fire Stop to the framing. Use screws to secure the Fire Stop/Trim Collar (TCS) or Fire Stop/Trim Plate (TPS).
- If the framed opening is larger than necessary, the Fire Stop (or JS) outer edge must be extended by appropriate means (attaching metal plates, 28 gauge galvanized steel or heavier) to completely block the framed opening from a vertical air flow around the chimney.

Enclose the chimney below the Fire Stop to prevent any accidental contact with the chimney. To prevent blown-in attic insulation from falling against the chimney, either use an Attic Insulation Shield (AIS) or a full enclosure in the attic. See Fig. 5.

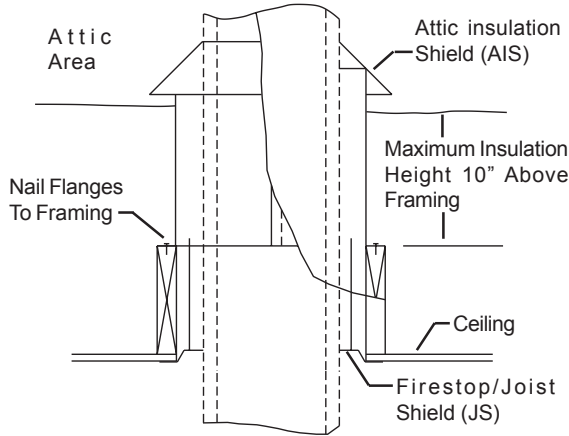

Fire Stop/ Joist Shield (JS) Used With Attic Insulation Shield

Fig. 5.

### CHIMNEYS IN ATTICS

In attics, either use an Attic Insulation Shield (AIS) or enclose the chimney. The chimney must be protected against the known contact hazards of insulation or stored combustible materials - mattresses, clothing, etc. Building a full enclosure is more effective but may be difficult and costly in tight spaces where there is little risk of accidental contact. For such situations the Attic Insulation Shield should be used.

**Protection against blown-in cellulose insulation is very important.**

### ATTIC INSULATION SHIELD

The function of the Attic Insulation Shield is to keep insulation away from contact with the chimney. Certain insulations made of cellulose fiber (old newspapers, processed wood) may ignite and smolder due to heat trapped by contact with the chimney. When this smoldering fire reaches ordinary wood framing, a flaming fire may result. However, even without a flame, a smoldering fire may create noxious gases and cause great property damage.

The Attic Insulation Shield (AIS) is not a Fire Stop and must be used with another part that is a designated Fire Stop. Parts that serve as Fire Stops include the Finish Support Package (FSP), Ceiling Support (CSP), Fire Stop/Trim Collar (TCS), Fire Stop/Trim Plate (TPS), Fire Stop/Wall Spacer (WS), and the Fire Stop/Joist Shield (JS). An installation above a Finish Support Package is shown in Fig.6.

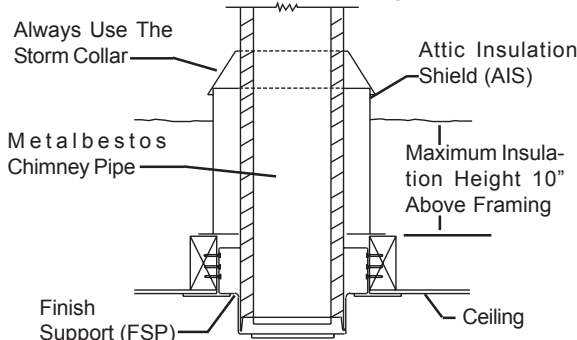

Attic Insulation Shield Used Over Finish Support

Fig. 6

### INSTALLATION OF THE ATTIC INSULATION SHIELD (AIS)

The Attic Insulation Shield for the Metalbestos chimney consists of two half cylinders, each with its own base plate, together with a Storm Collar (SC) closure at the upper end. See Fig. 7. For retrofit installation the Attic Insulation Shield may be placed through openings between 16 inch on center ceiling joists. It is also adaptable to limited headroom installations near eaves of roofs where it can be slid into place, or the two halves can be dropped through a roof opening and placed around the chimney.

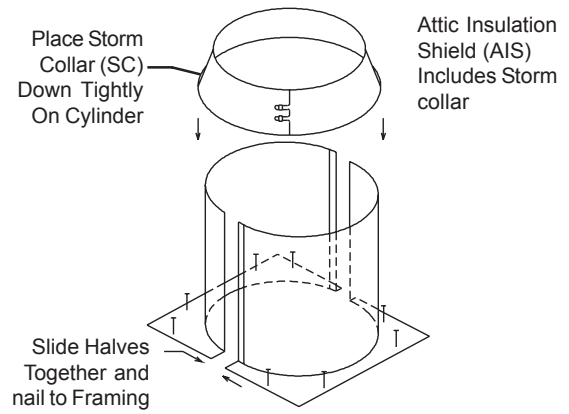

Attic Insulation Shield

Fig. 7

For proper installation, the attic opening should be fully framed at 2 inches clearance to the chimney pipe with framing material of the same dimension as the ceiling joists. The square base in the Attic Insulation Shield is placed on the framed opening around the chimney, with the adjoining vertical edges fully together. The storm collar is then placed tightly down over the upper open end of the cylinder. Nail the AIS base to the framing with at least 2 nails per side.

The split cylinder low profile design of the Attic Insulation Shields permits it to be used close to eaves and side walls as shown in Fig. 8. If there is sufficient clearance the storm collar should be used. If the cylindrical shield projects through the roof it should be trimmed flush with the roof surface so it does not interfere with the flashing.

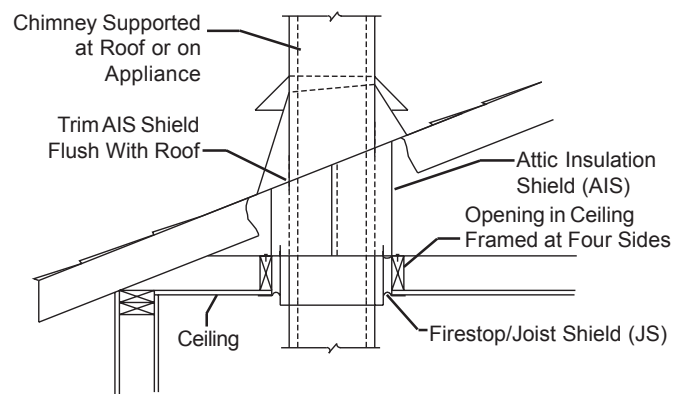

Intallation Of Attic Insulation Shield Near Eaves

Fig. 8

Instead of using the Attic Insulation Shield the chimney installer always has the option of fully enclosing the chimney between the ceiling framing and the roof. This enclosure should be any standard material such as drywall or plywood, at the required 2-inch clearance.

The Attic Insulation Shield allows for a depth of insulation up to 10 inches plus the depth of the ceiling joists. At this depth, the insulation will be approximately 4 inches below the lower edge of the storm collar.

If insulation is blown in and adheres to the chimney pipe or the storm collar, it should be brushed off to eliminate any possible contact of this material with the chimney surface.